

P-OUFR-L-MAX SERİSİ

Graphic Symbol

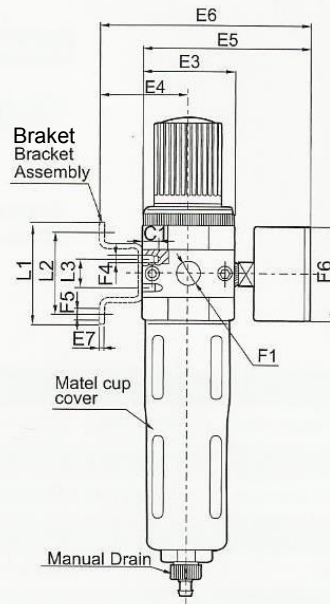
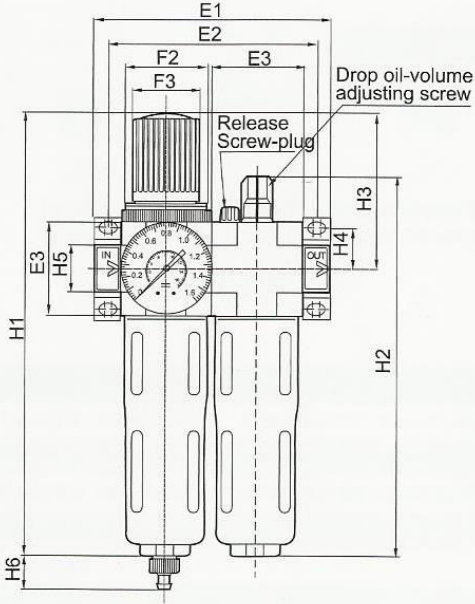
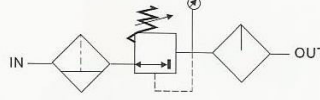

MODELLER / MODELS

- P-OUFR-L –MIDI / 1/8" BAĞLANTILI / THREADED
- P-OUFR-L-MIDI / 1/4" BAĞLANTILI / THREADED
- P-OUFR-L-MIDI / 3/8" BAĞLANTILI / THREADED
- P-OUFR-L-MIDI / 1/2" BAĞLANTILI / THREADED
- P-OUFR-L-MAX I / 3/4" BAĞLANTILI / THREADED
- P-OUFR-L-MAX I / 1" BAĞLANTILI / THREADED

MAX BASINÇ / MAX.PRESSURE : 10 BAR
 MAX SICAKLIK / MAX.TEMPERATURE : 60 °C
 TAHLİYE YARI OTOMATİK / DISCHARGE SEMI-AUTO
 FILTRASYON / FILTRATION : 5 MİKRON

TİP / MODEL	E1	E2	E3	E4	E5	E6	E7	F2	F1	F3Ø	F4	F5Ø	F6Ø	L1	L2	L3	H1	H2	H3	H4	H5	H6
P-OUFR-L –MIDI 1/8"	140	125	55	47	93	112	3	M52*1.5	1/8"	50	M5	5.5	52	71	60	22	250	206	97	24.5	32	15
P-OUFR-L –MIDI 1/4"	140	125	55	47	93	112	3	M52*1.5	1/4"	50	M5	5.5	52	71	60	22	250	206	97	24.5	32	15
P-OUFR-L –MIDI 3/8"	140	125	55	47	93	112	3	M52*1.5	3/8"	50	M5	5.5	52	71	60	22	250	206	97	24.5	32	15
P-OUFR-L –MIDI 1/2"	140	125	55	47	93	112	3	M52*1.5	1/2"	50	M5	5.5	52	71	60	22	250	206	97	24.5	32	15
P-OUFR-L –MAXI 3/4"	162,182	146,157	66	53	104	124	3	M36*1.5	3/4"	31	M5	5.5	63	71	60	22	252	223	80	24.5	32,4	15
P-OUFR-L –MAXI 1"	162,182	146,157	66	53	104	124	3	M36*1.5	1"	31	M5	5.5	63	71	60	22	252	223	80	24.5	32,4	15